

NOR-FAB

BUILDING COMPONENTS LTD

PRE-CUT E-Z BUILD KIT 12'x8' BARN

TOOLS REQUIRED:

HAMMER,
TAPE MEASURE,
LEVEL, ROBERTSON
& PHILLIPS
SCREWDRIVER,
LADDER

SIZES ARE NOMINAL



REMEMBER:

CHECK FOR
UNDERGROUND
LINES BEFORE
DIGGING.

IN MANY AREAS
BUILDING PERMITS
ARE NOT REQUIRED
FOR SMALL STORAGE
BUILDING.

PLEASE CHECK
WITH YOU LOCAL
OFFICIALS BEFORE
CONSTRUCTION.

1. GENERAL

Prior to beginning construction the area selected for the shed must be level and clear.

2. INVENTORY

Unpack all the parts from the kit and lay them out into separate piles, matching up lengths and sheeting sizes to ensure you have everything for the project.

3. FRAME PREPARATION

Find the two treated 2"x4"x7'-11" and place on their edge together. Mark out the rim joist as shown in **Figure 1**. Place the rim joist on the ground in the area where you are building the storage shed roughly 12' apart on their edge.

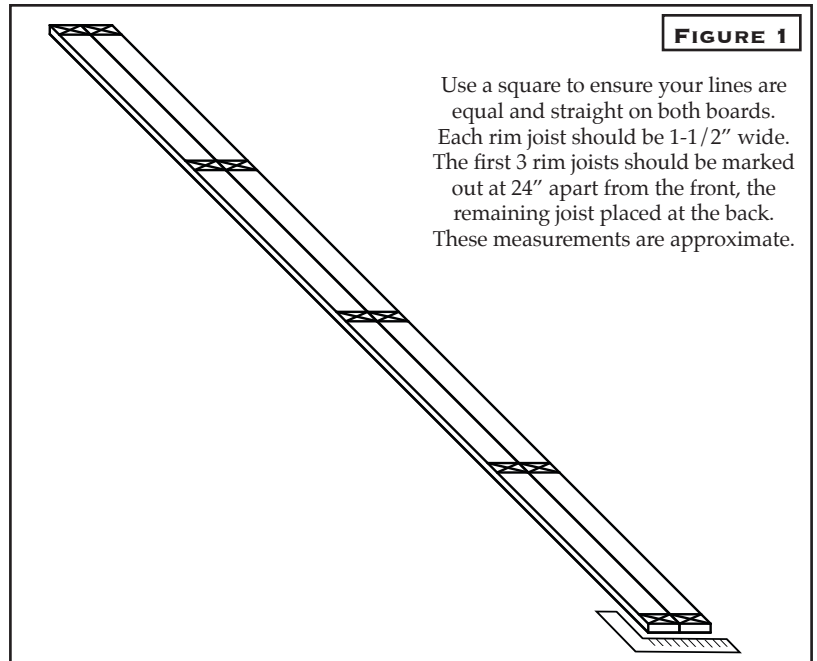

NOR-FAB BUILDING COMPONENTS LTD

TOLL FREE: 800-465-2918 CUSTOMER SERVICE: 807-274-7401 EXT: 223

4. FRAMES

Unfold the shed frames and nail on supplied plywood gussets at folding joints. (Peak and bottom cord.)

5. FRONT WALL

Stand up front and nail through rim joist into the frame. Use braces to help keep frames standing safely.

Figure 2.

6. FRAMING

Repeat the steps adding the remaining frames standing them up and nailing them through the rim joist. Use supports to hold frames 24" apart from each other.

Figure 2.

7. FLOOR BRACING

Nail in all treated 2"x4" floor bracing as shown in Figure 3 using 3" nails.

8. FLOOR SHEETING

Place in the 3/4" treated floor sheeting as shown in Figure 4. Next nail sheeting down to the floor with 2" nails that are supplied.

Figure 4.

9. BACK WALL FRAMING

Install the horizontal headers on the front wall using parts I & H. Install back wall header using parts B & C. Nail plywood gussets to the inside of the frames to hold splice together.

Figure 5.

10. WALL FRAMES

Finish installing the rest of the front and back wall framing using Figure 5 corresponding the part letters and measurements to their positions. Toenail the bottom of parts A & G on top of the sheeting into the floor, then toenail parts F, E, D, J, K into the top of the frame.

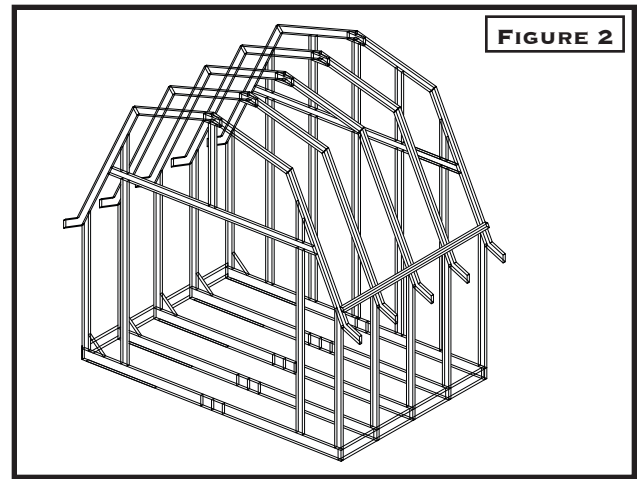

FIGURE 2

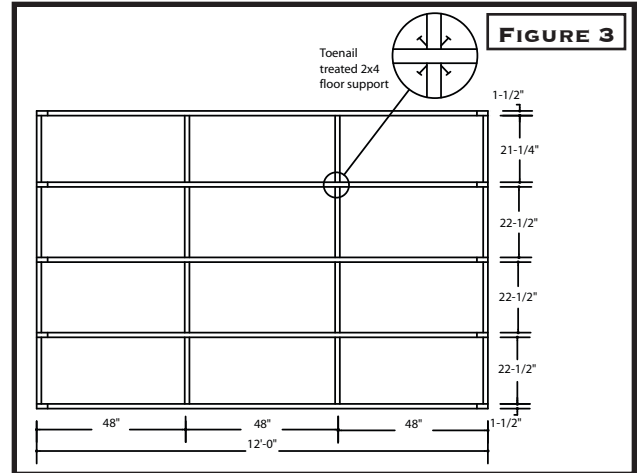

FIGURE 3

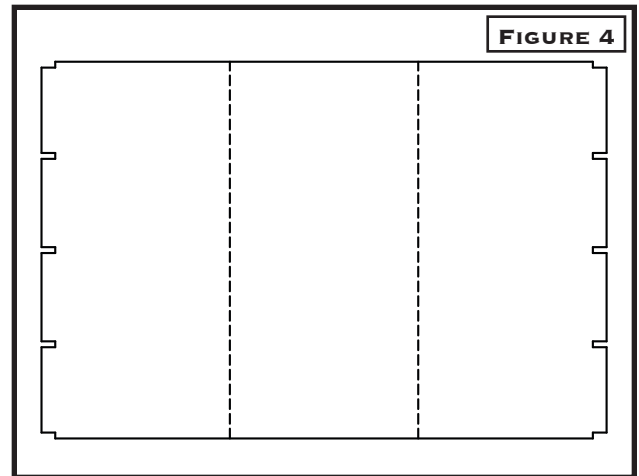

FIGURE 4

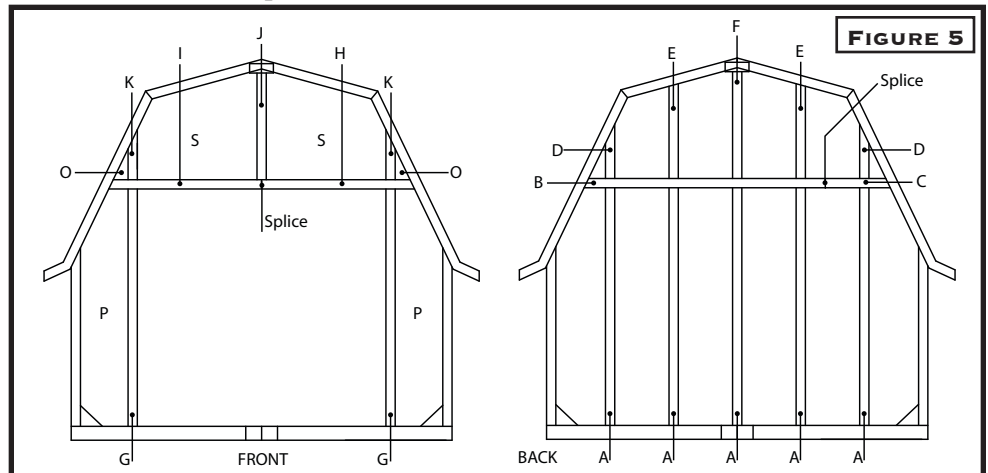

FIGURE 5

11. SHEETING

Sheet the back wall with the T1-11 siding beginning at the top of the back wall with part Q matching parts R to Q then moving on to parts L, M, N shown in **Figure 6**.

12. WALL FRAMES

Sheet the front wall the same as the back wall, starting with part S matching parts O up to S finishing with parts P as shown in **Figure 5**.

13. SIDING

Begin sheeting the side walls with 4'x5'-11" T1-11 siding starting at the front of the shed to the back. Install the 2"x4" blocking in between the frames and the top of the siding to seal off the soffit of your building.
header trim.

14. FASCIA

Begin to nail in your 1"x4" fascia starting with the side fascia 1"x4"x95". See **Figure 7** for details on how to nail into the correct position. Sort out the remaining 1"x4" trim and nail on the front and rear fascia starting with the top roof, middle roof fascia and lastly the bottom roof fascia or eave fascia. Install the corner and header trim.

15. ROOF SHEETING

Next install the roof sheeting the three different sizes of roof sheeting. Start with the bottom roof section or eave tail section nailing on the 8'-1/4"x8' OSB sheeting. Next move to the middle roof pieces 4'x8' and 2'x8' then onto the top roof 3'-9-1/2".

16. DOORS

Hang the door with the t-hinges supplied in the kit keeping both doors level with each other and the opening.

17. FINISH

Shingle, paint and enjoy your 12'x8' EZ Build Storage Building.

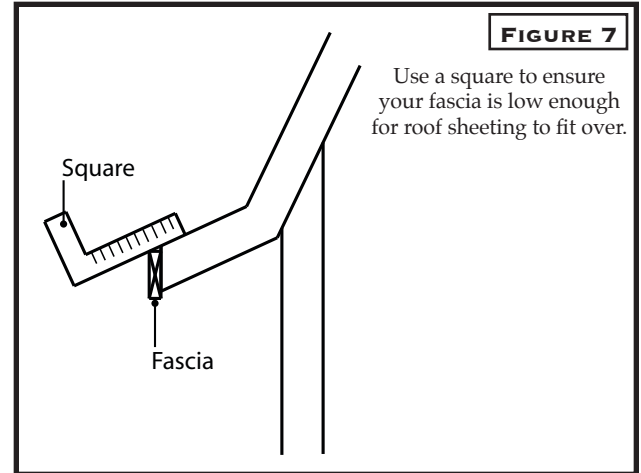
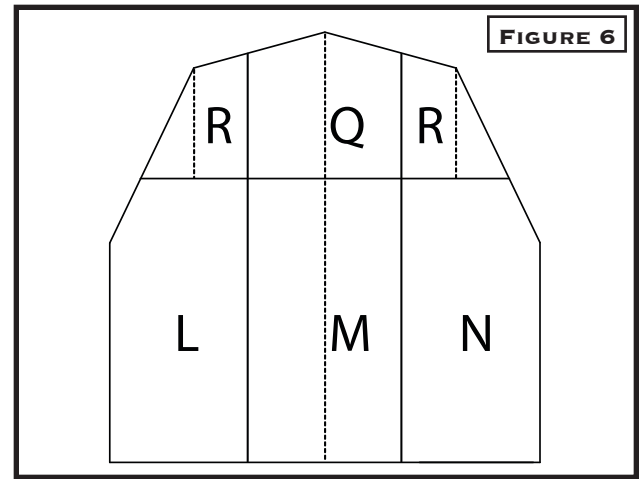

12X8

E-Z

BUILD

BARN - 2006

FLOOR

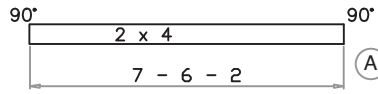

5 - BACK BOTTOM STUDS

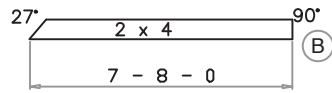

1 - TOP BACK PLATE LEFT SIDE

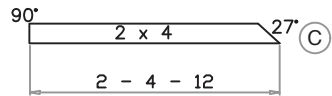

1 - TOP BACK PLATE RIGHT SIDE

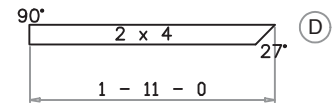

2 - BACK TOP STUDS RIGHT AND LEFT

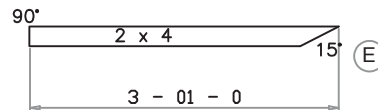

2 - BACH TOP STUDS RIGHT AND LEFT

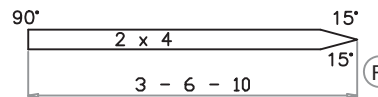

1 - CENTER TOP STUD

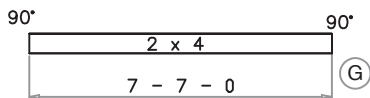

2 - FRONT WALL STUDS

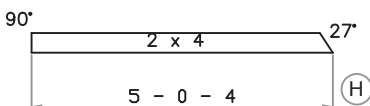

1 - FRONT TOP PLATE RIGHT SIDE

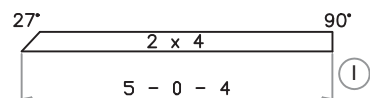

1 - FRONT TOP PLATE LEFT SIDE

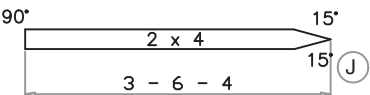

1 - FRONT CENTER TOP SITUD

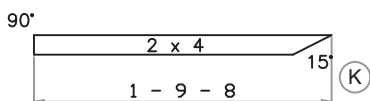

2 - FRONT TOP STUDS RIGHT AND LEFT

3 - 5/8" x 4"x8" TREATED PLYWOOD

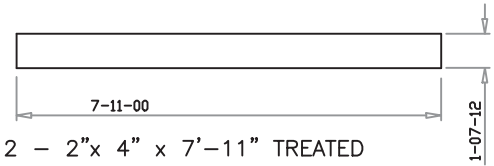

2 - 2"x 4" x 7'-11" TREATED

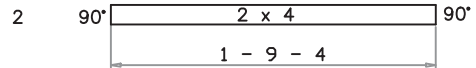

2

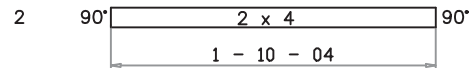

2

SOFFIT OR BUG BOARD

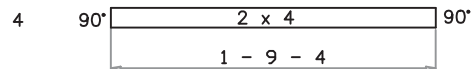

4

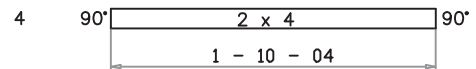

4

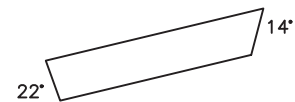

4 - 3'-9 "3/4" FRONT FASCIA RIGHT AND LEFT

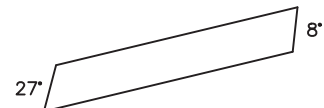

4 - 5'-11 "3/4" FRONT FASCIA RIGHT AND LEFT



4 - 1'-0 "1/4" FRONT FASCIA RIGHT AND LEFT



4 - 6'-6 "1/4" FASCIA RIGHT AND LEFT

ZONE	REV	DESCRIPTION	DATE: 2005-06	APPROVED
		SIZE FSCM NO. DWG NO. 001		REV
		SCALE NTS DWG BY P.A.C.	SHEET 1	



12X8 E-Z BUILD BARN - 2006

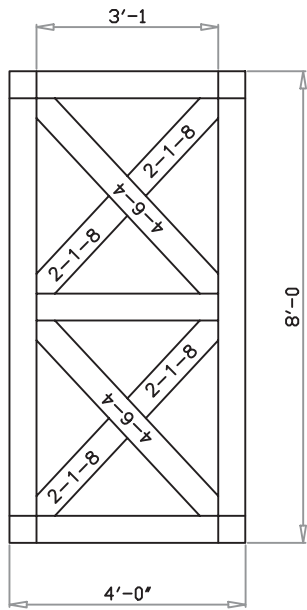

DOOR FRAME
 RIGHT AND LEFT (1x6)
 TOTAL
 4 - 1"X6" x 8'-0" 90°
 6 - 1"X6" x 3'-1" 90°

2 - REQUIRED
 RIGHT AND LEFT

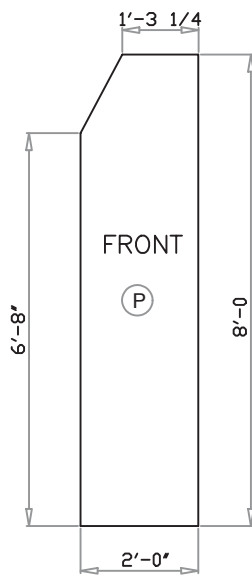

FRONT

(P)

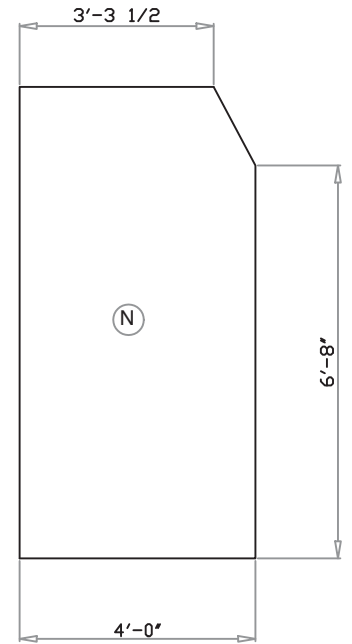
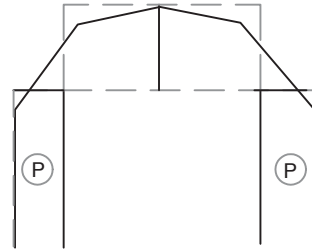
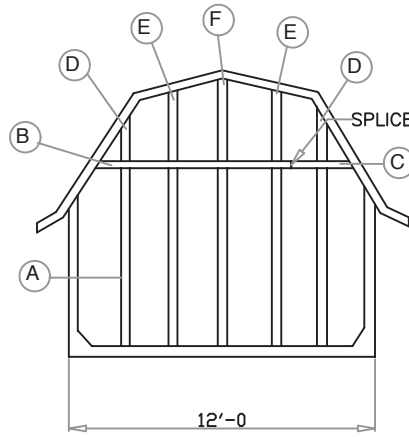

(N)

2 - REQUIRED
 RIGHT AND LEFT

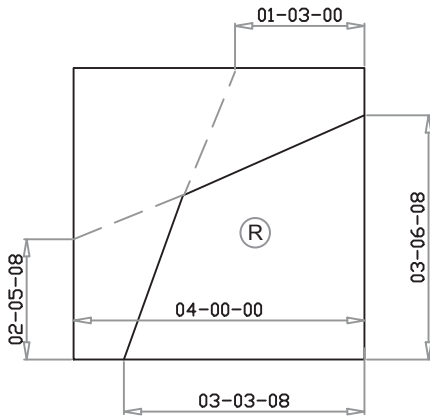

LEFT SIDE - BACK

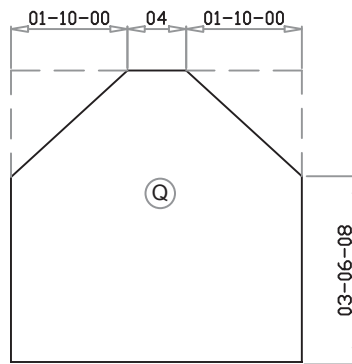

CENTER SHEET

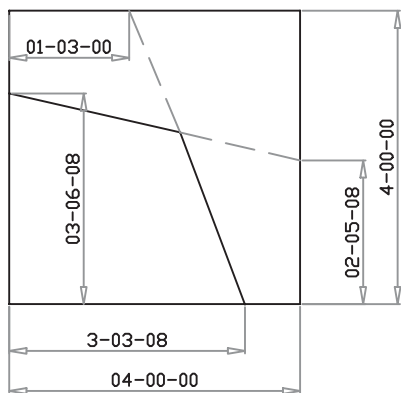
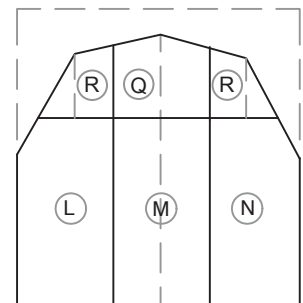

RIGHT SIDE BACK

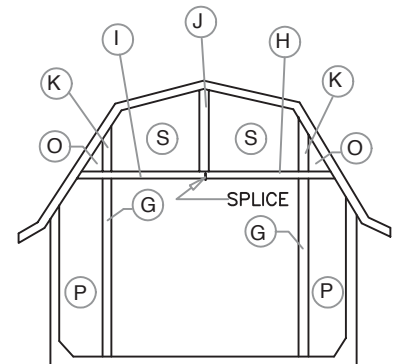

DESCRIPTION				DATE: 2005-06	
SIZE	FSCM NO.	DWG NO.	001		
SCALE	NTS	DWG BY	P.A.C.		SHEET 2



12X8 E-Z BUILD BARN - 2006

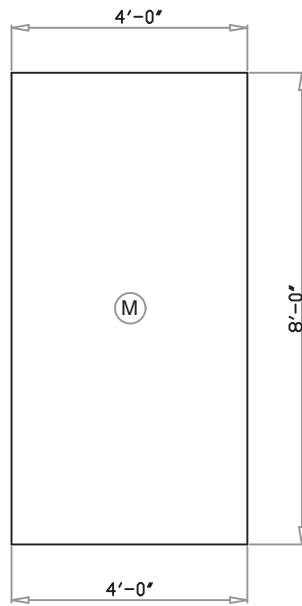
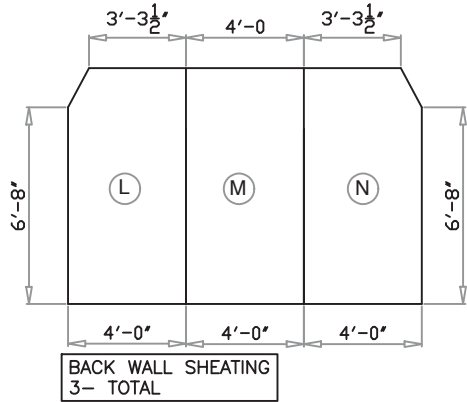

DOOR SHEATHING
RIGHT AND LEFT
4'-0" X 8'-0"
TOTAL - 2

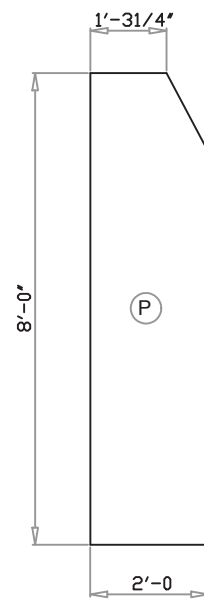

FRONT WALL SHEATHING
RIGHT AND LEFT
TOTAL - 2

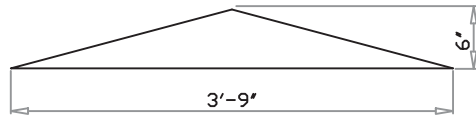

GUSSETS
EZ - PANEL
TOTAL OF - 8 REQUIRED

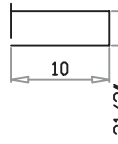

FLOOR GUSSETS
PLYWOOD
TOTAL OF - 8 REQUIRED

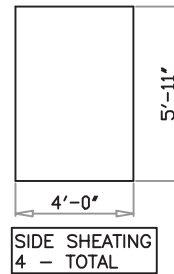

SIDE SHEATHING
4 - TOTAL

ROOF PLYWOOD O.S.B.

TOTAL: HIGH ROOF
2 3'-9 1/2" x 8'-0"

LOW ROOF
2 4'-0" x 8'-0"
2 2'-0" x 8'-0"

OVERHANG LOWER ROOF
2 - 8 1/4" x 8'-0" x 5/8"
OSB PLYWOOD

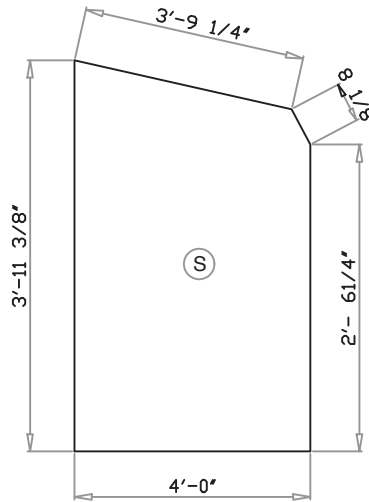

TOP FRONT WALL SHEATHING
2 - REQUIRED
RIGHT AND LEFT

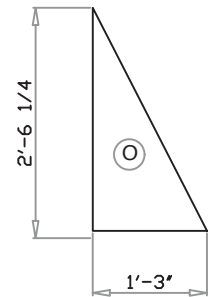

2 - REQUIRED
RIGHT AND LEFT

	ZONE	REV	DESCRIPTION	DATE: 2005-06	APPROVED
			SIZE	FSCM NO.	DWG NO. 001
			SCALE NTS	DWG BY P.A.C.	REV
					SHEET 3

