

10 Ft ELITE GAZEBO

INSTRUCTIONS FOR ASSEMBLY

Check parts carefully to ensure all parts are in the kit. Do not call the store with problem or missing parts. Contact Norfab Immediately at 1 800 465 2918 and they will look after you.

Updated September 5, 2001

Tools required for construction: hammer, Philips and No. 2 - Robertson screwdrivers or drill bits, utility knife, step ladder, tape measure, saw, stapler, and sand paper.

PLEASE READ INSTRUCTIONS CAREFULLY

Step 1:

Make sure that the construction site is large enough to accommodate the gazebo. The structure when completed is 9'6" high and is 10' in diameter. The building site must be level to ensure proper fit of gazebo components.

Step 2:

Unpack the gazebo. Please handle the lattice panels carefully. Use the materials list, found at the end of these instructions, to identify each part and group all floor sections, wall panels, and roof components in their respective groups. If you have any questions please contact Norfab at 1-800-465-2918 between 8:00 a.m. - 5:00 p.m., Monday to Friday and 8:30 a.m.- 3:30 p.m. Saturday, Central time.

Step 3:

Lay out the floor sections in the desired location as arranged in the diagram to the right. Be certain that one of the sides of the hexagon is facing the desired direction of the door.

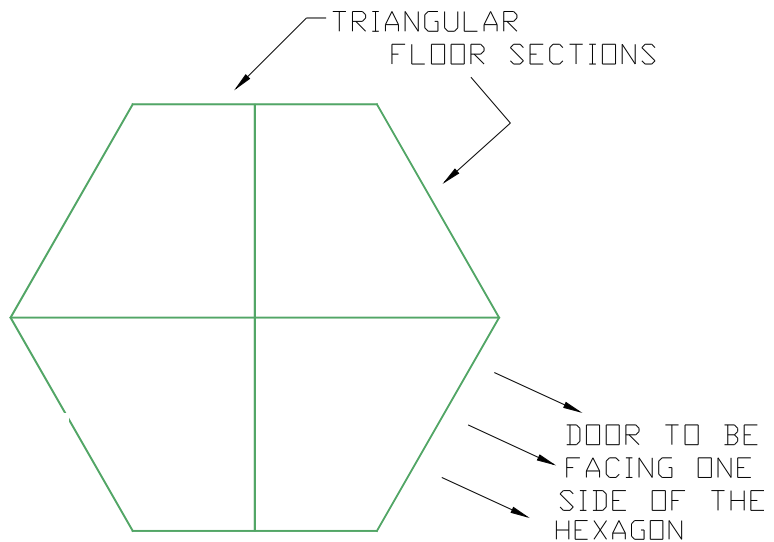

The floor system must be blocked up to

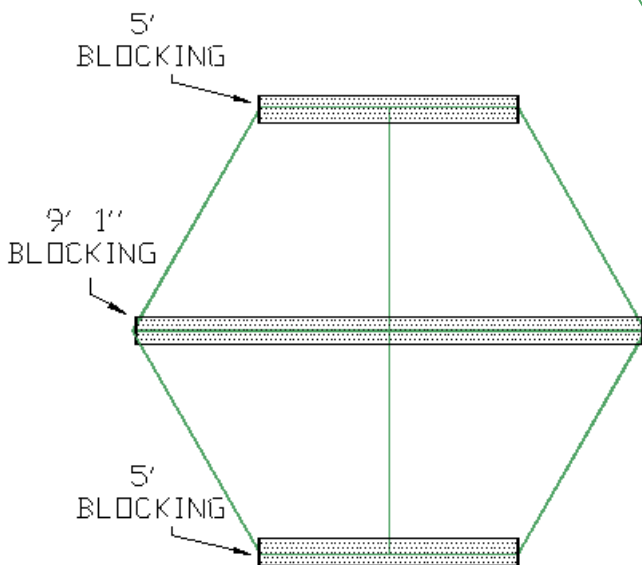

ensure a level base. The diagram to the left shows the suggested blocking. The blocking materials recommended (not supplied) are one 10' long 4"x 4" pressure treated timber and two 5' long 4"x 4" pressure treated timbers. Cut the 10' timber to 9'1". (Concrete or wood blocks are also suitable blocking. Seven blocks should be used to properly support the floor system.)

10' ELITE Gazebo

- Page 1 -

Once the floor sections are blocked and level, nail seams of the four triangular frames together with one row of 3" nails at 12" on center from both sides as shown here.

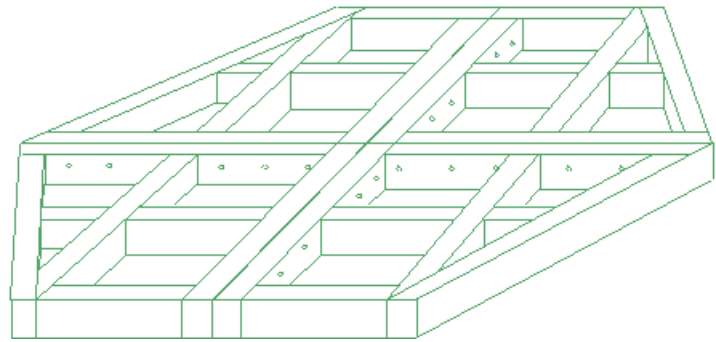

Step 4:

Sheath the floor sections with the 5/8" thick treated plywood provided. Butt the large center sheets together at the center of the gazebo floor as illustrated to the right. Use the 2" nails for nailing the plywood to the frame. Please note that small gaps around the perimeter of the frame are normal and will not effect the assembly, nor appearance of your gazebo.

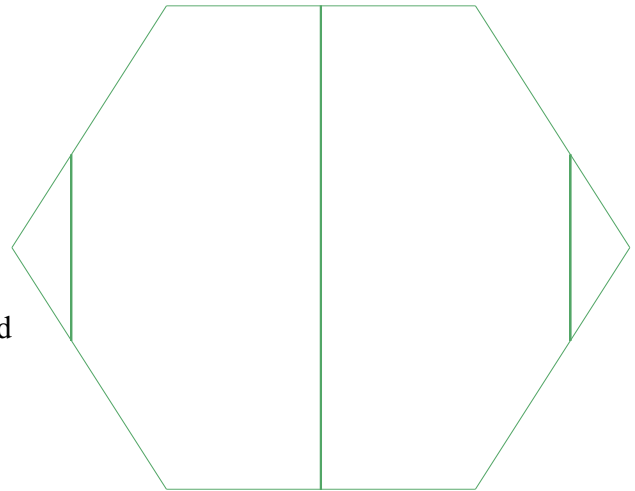

Step 5:

Stand up the door panel in its desired location, keeping the outside of the framing flush with the edge of the floor framing. Erect the remaining panels, fastening them together with three 3" screws, one at the top, middle and bottom of each wall panel. After all wall panels have been erected nail each section to the floor with two 3" nails. If the panels do not line up properly, check blocking to ensure the floor system is level.

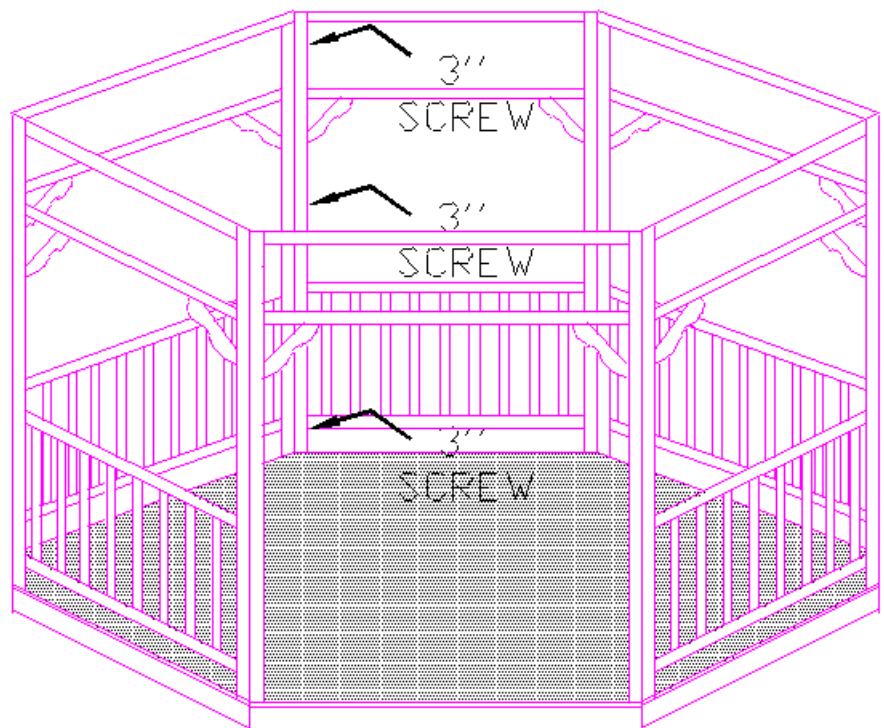

Step 6:

Install the lattice panels in the top portion of each wall panel, flush with the outside of the frame. Hang gate level with adjacent wall railings using the hinges and door latch provided, and install them in the locations illustrated below.

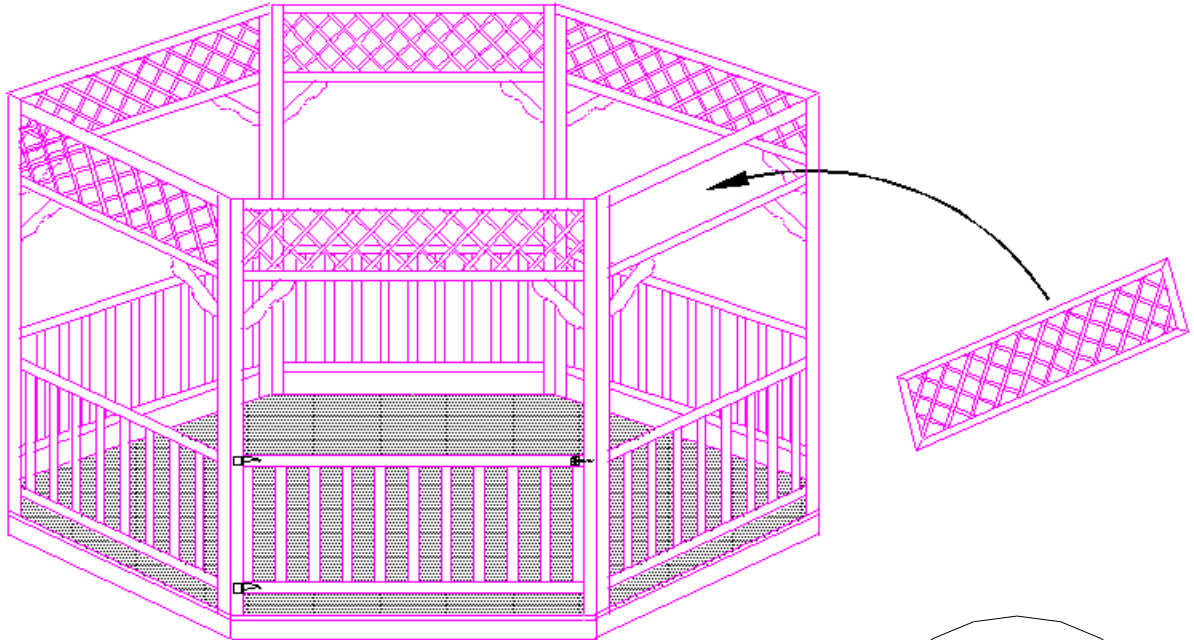

Step 7:

To erect the roof, take the roof peak (piece of 2 7/8" pipe, 3 3/4" long) and screw two rafters to it on opposite sides of the pipe using two screws for each rafter, keeping top of pipe flush with top of rafter. Place the two assembled rafters across the gazebo diagonally at the panel joints. The notch at the tail end of the rafter should fit snug against the outer edge of the wall perimeter. Make sure the center of the rafters line up with the panel joints. If the notch does not fit snug, either push wall out or the roof peak up, to make them fit well.

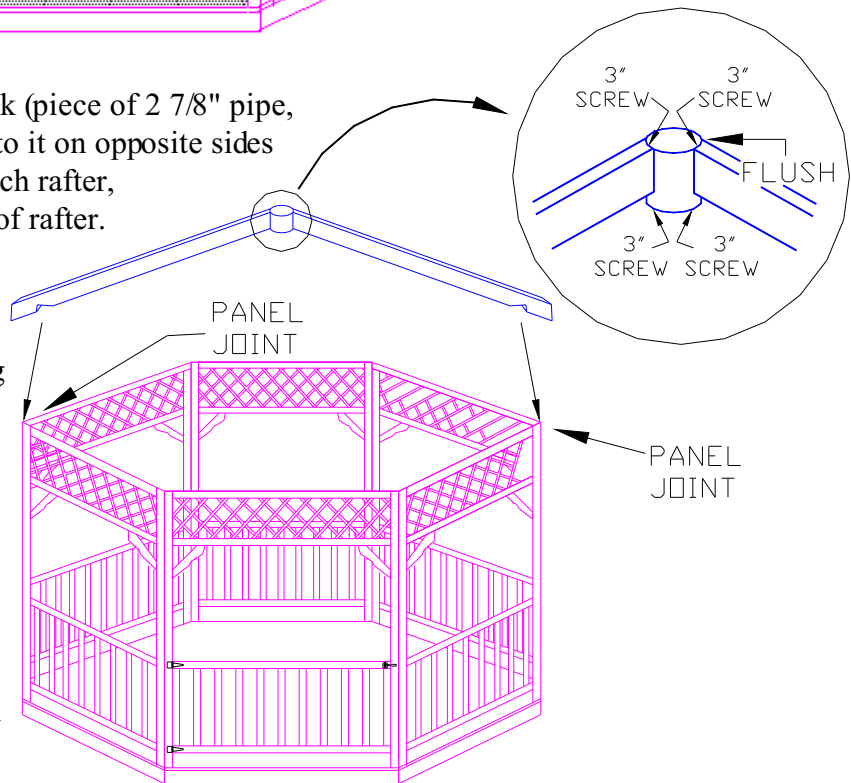

Fasten each rafter to the wall panel joints with 3" nails. Fasten

remaining rafters to roof peak with two screws in each rafter and two nails fastening rafter to wall perimeter.

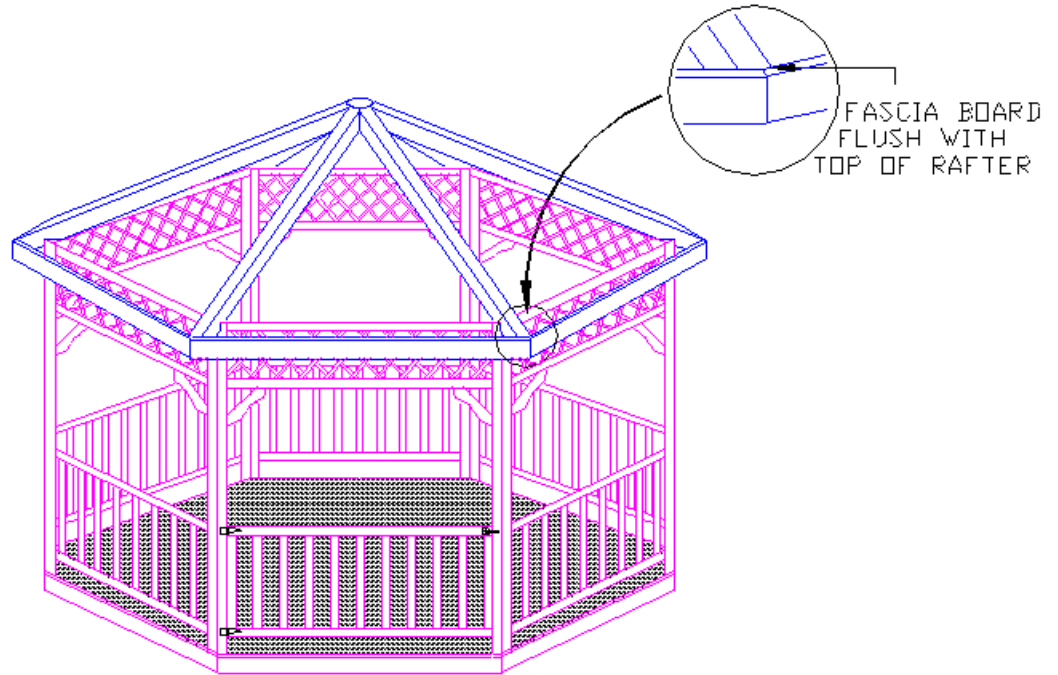

Step 8:

Install wavy edge fascia boards (Shown with straight edge). The top of the fascia board should be flush with the top of the rafter.

Step 9:

Sheath the roof with 1/2" plywood, keeping the bottom edge of the plywood flush with the fascia. It is important when installing the roof sheathing that each section of plywood meets its adjacent section at the center of each roof rafter. Install all of the largest sheets of plywood first, insert H clips (not shown) between the large and small sheets, and then proceed to install the triangular pieces at the peak of the roof, and finally the small wedges at the base of the roof. If you climb on the roof for any reason, distribute your weight onto the roof rafters. Shingle roof with your choice of shingles.

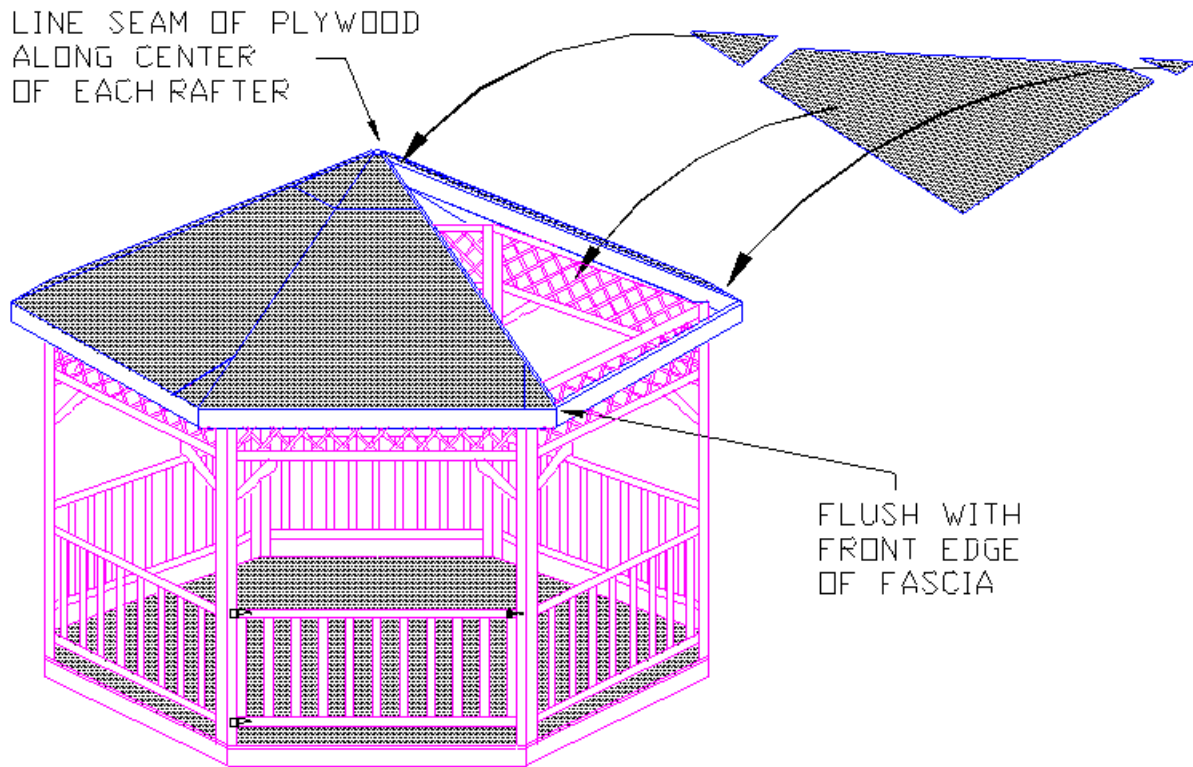

Step 10:

Nail a vertical corner board to each wall panel joint, between the vertical 2"x 4" posts, using finishing nails. Also using finishing nails, attach the cedar floor fascia to the base of each wall panel.

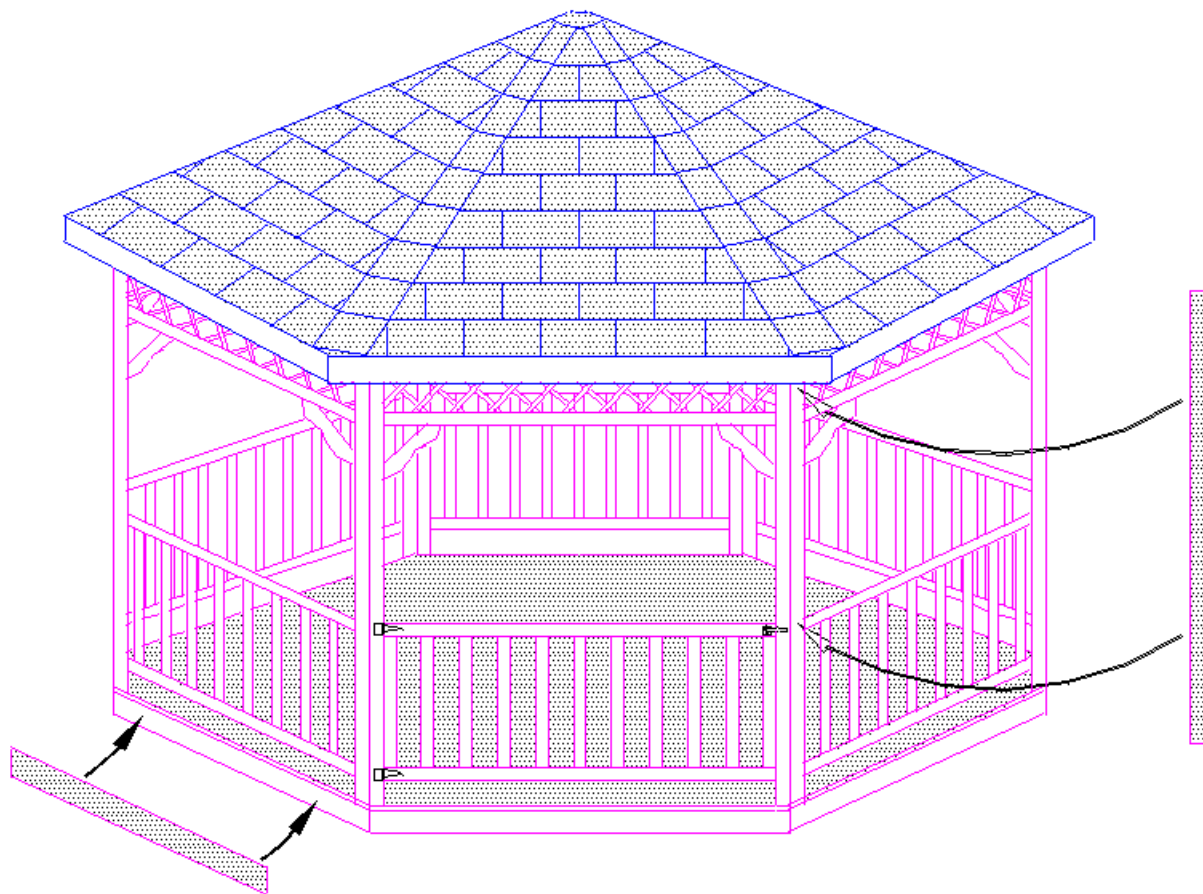

Step 11:



To preserve the beauty of your cedar Gazebo you must stain or varnish it within a few days of installation. You may want to sand any rough edges, and stamps, to produce a better finish.



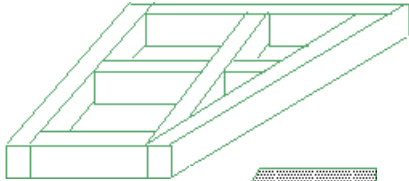
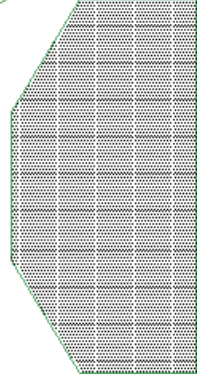

Step 12.

Install your cedar roofing material.

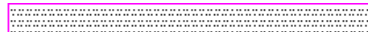
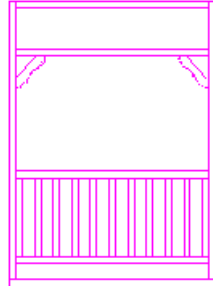
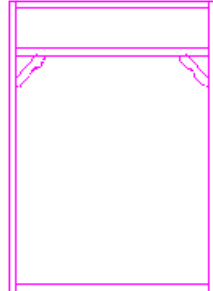
Materials List for the 10' MONARCH Gazebo

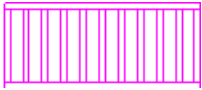
Check all parts carefully! If you experience any problems do not call the store! Call Norfab immediately at 1 800 456 2918 and they WILL look after you.

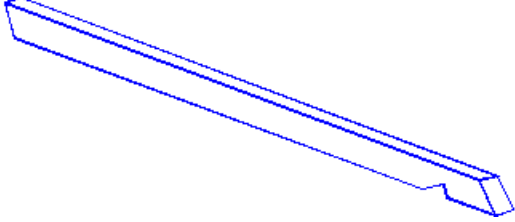
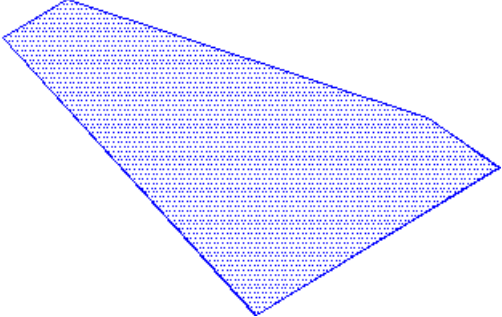
	QTY	DESCRIPTION	
Floor system:	4	Triangular floor sections	
	2	Pieces 5/8" treated plywood	
	2	Triangular 5/8" treated plywood	
	6	Cedar floor fascia	
Wall Panels:	5	Wall panels	
	1	Door panel	

	6	Lattice panels	
	1	Gate	
	6	Cedar corner boards	
Roof Components:			
	1	Roof peak (2 7/8" piece of 3" pipe)	
	6	Cedar rafters	
	6	1/2" plywood sheathing With cedar interior attached	
	6	Cedar wavy edge fascia boards (shown as straight edge)	

- Other:**
- 12 H clips
 - 1 Gate latch and hinges
 - 1 Bag 3" nails
 - 1 Bag 2" nails
 - 1 Bag finishing nails
 - 1 Bag 3" screw
 - 1 Cedar 2 - Tier roof

Inspected by: _____ Date: _____